



15



XM

840.011

1

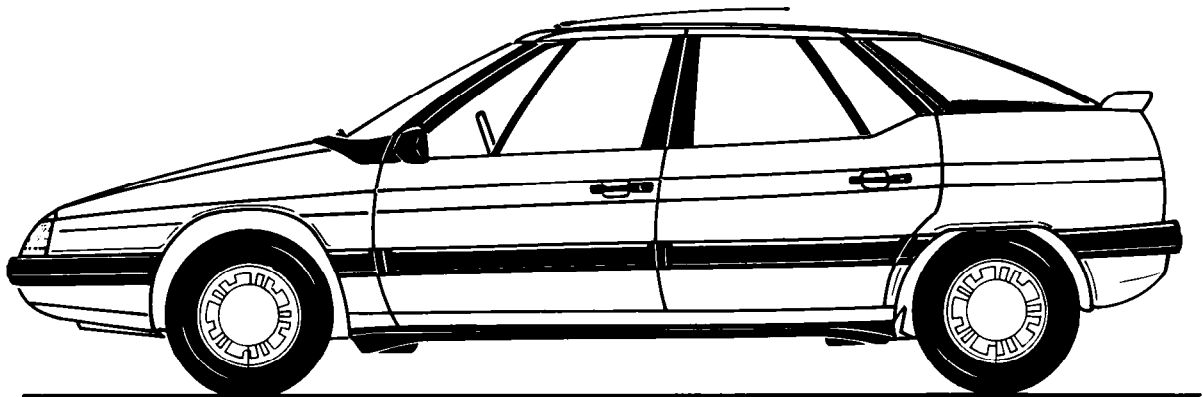

Y.80-5

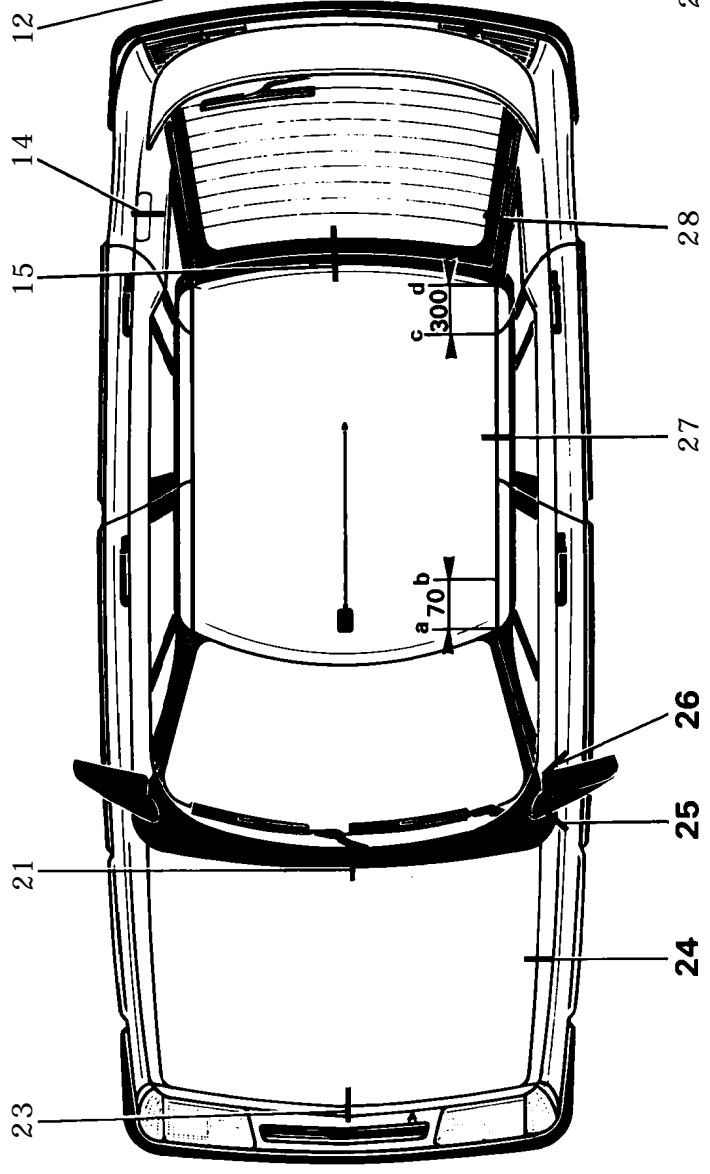
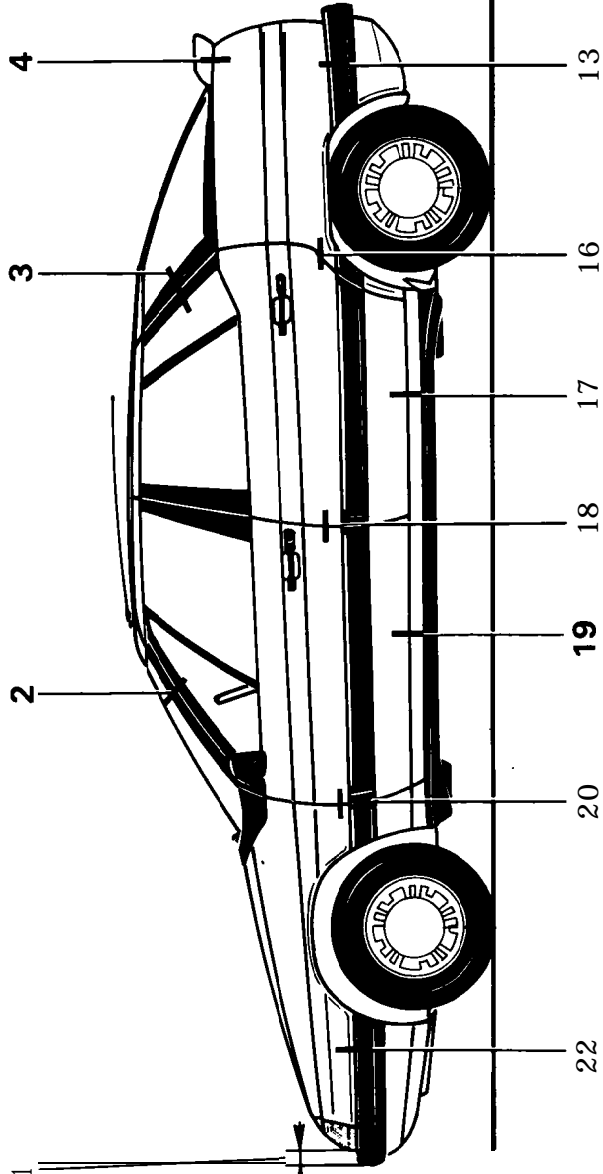
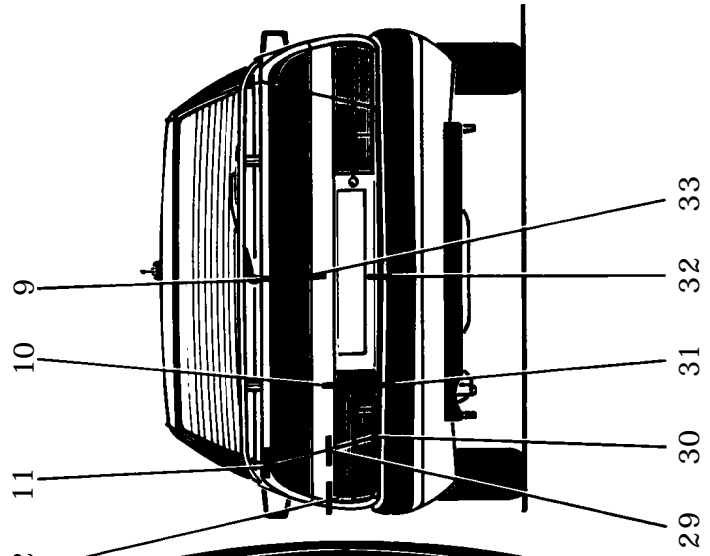
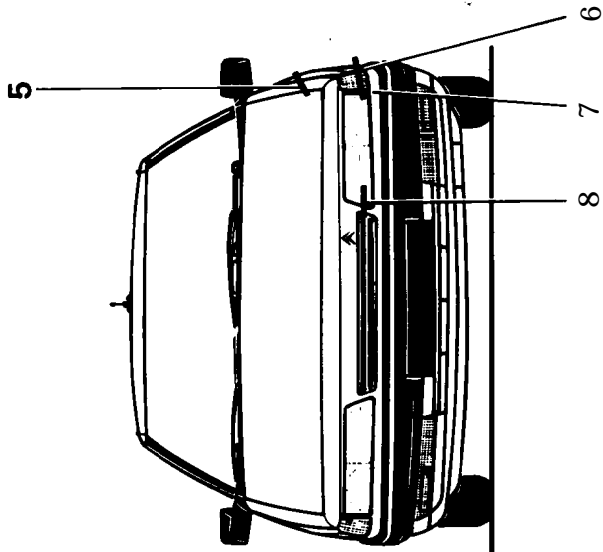

c d 300

a b 70



15

X M
840-0/1

3

Nr	Detalj	Spel	Nivåskillnad	Parallellfel
1	Stötfångare - gallerplåt	45		max 2,5
2	A-stolpe - framdörr	$4 \begin{smallmatrix} +2 \\ 0 \end{smallmatrix}$	±2	max1
3	Bakdörr - bakre sidostycke	$4 \begin{smallmatrix} - \\ +2 \end{smallmatrix}$	max1	max1
4	Spoiler - bakskärm	$7 \begin{smallmatrix} - \\ +2 \end{smallmatrix}$		max1
5	Galler - framskärm	$0 \begin{smallmatrix} +1 \\ 0 \end{smallmatrix}$	$0 \begin{smallmatrix} - \\ -0,5 \end{smallmatrix}$	
6	Framsärm - gallerplåt	0	+0,5	max 0,5
7	Lykta - strålkastare	$0 \begin{smallmatrix} - \\ +1,5 \end{smallmatrix}$	f l	max1
6	Strålkastare - gallerplåt	$3 \begin{smallmatrix} - \\ +1 \end{smallmatrix}$	f l	max1
9	Övre randparti - baklucka	$3 \begin{smallmatrix} +1 \\ 0 \end{smallmatrix}$	max1	max1
10	Ljus i baklucka - randparti	$4 \begin{smallmatrix} +1 \\ 0 \end{smallmatrix}$	max1	max1
11	Baklucka - bakskärm	$4 \begin{smallmatrix} +2 \\ 0 \end{smallmatrix}$	max1	max1
12	Bakskärm - ljus i bakluckan	$3 \begin{smallmatrix} +1 \\ 0 \end{smallmatrix}$	max1	max1
13	Bakskärm - stötfångare	$6 \begin{smallmatrix} +2 \\ 0 \end{smallmatrix}$		max1
14	Bensinlucka - bakskärm	$2,5 \pm 0,5$	$0 \begin{smallmatrix} - \\ -0,5 \end{smallmatrix}$	
15	Tak - baklucka	$5 \begin{smallmatrix} - \\ +2 \end{smallmatrix}$	+0	max1
16	Bakdörr - bakskärm	$4 \begin{smallmatrix} +2 \\ 0 \end{smallmatrix}$	max1	
17	Tröskelbalk - underkant på framdörr	$6 \begin{smallmatrix} +2 \\ 0 \end{smallmatrix}$	$0 \begin{smallmatrix} - \\ -2 \end{smallmatrix}$	max1
16	Framdörr - bakdörr	$4 \begin{smallmatrix} - \\ +2 \end{smallmatrix}$	max1	max1
19	Tröskelbalk - underkant på framdörr	$6 \begin{smallmatrix} - \\ +2 \end{smallmatrix}$	$0 \begin{smallmatrix} - \\ -2 \end{smallmatrix}$	max1
20	Framsärm - framdörr	$4 \begin{smallmatrix} - \\ +2 \end{smallmatrix}$	max1	
21	Motorhuv - luftintag	$4 \begin{smallmatrix} - \\ +2 \end{smallmatrix}$	+0	max1
22	Framsärm - gallerplåt - främre stötfångare	$6 \begin{smallmatrix} +2 \\ 0 \end{smallmatrix}$		max1
23	Motorhuv - gallerplåt	$4 \begin{smallmatrix} - \\ +2 \end{smallmatrix}$	-0,5	max1
24	Motorhuv - framsärm	$4 \begin{smallmatrix} - \\ +2 \end{smallmatrix}$	0	max1
25	Luftintag . luftintagets ändstycke	4 ± 2	+0,5	max 0,5
26	Luftintagets ändstycke - vindrutans sidodelar	3 ± 1		
27	Tak - dörrar $4 \begin{smallmatrix} + \\ 0 \end{smallmatrix}$ vid "a" gradvis tilltagande till $8 \begin{smallmatrix} + \\ 0 \end{smallmatrix}$ vid "b", konstant från "b" till "c", gradvis avtagande till $4 \begin{smallmatrix} + \\ 0 \end{smallmatrix}$ vid "d".	$8 \begin{smallmatrix} +2 \\ 0 \end{smallmatrix}$	f l	max1
26	Baklucka - bakre sidostycke	$4 \begin{smallmatrix} +2 \\ 0 \end{smallmatrix}$	±2	max1
29	Bakljus - baklucka	$6 \begin{smallmatrix} +2 \\ 0 \end{smallmatrix}$	max1	max1
30	Bakljusets dekorram - baklucka	$5 \begin{smallmatrix} +2 \\ 0 \end{smallmatrix}$	max1	max1
31	Ljus i baklucka - baklucka	3	max1	max1
32	Bakre stötfångare - baklucka	$6 \begin{smallmatrix} +2 \\ 0 \end{smallmatrix}$		max1
33	Randparti - övre randparti	$2 \begin{smallmatrix} +2 \\ 0 \end{smallmatrix}$	max1	max1